

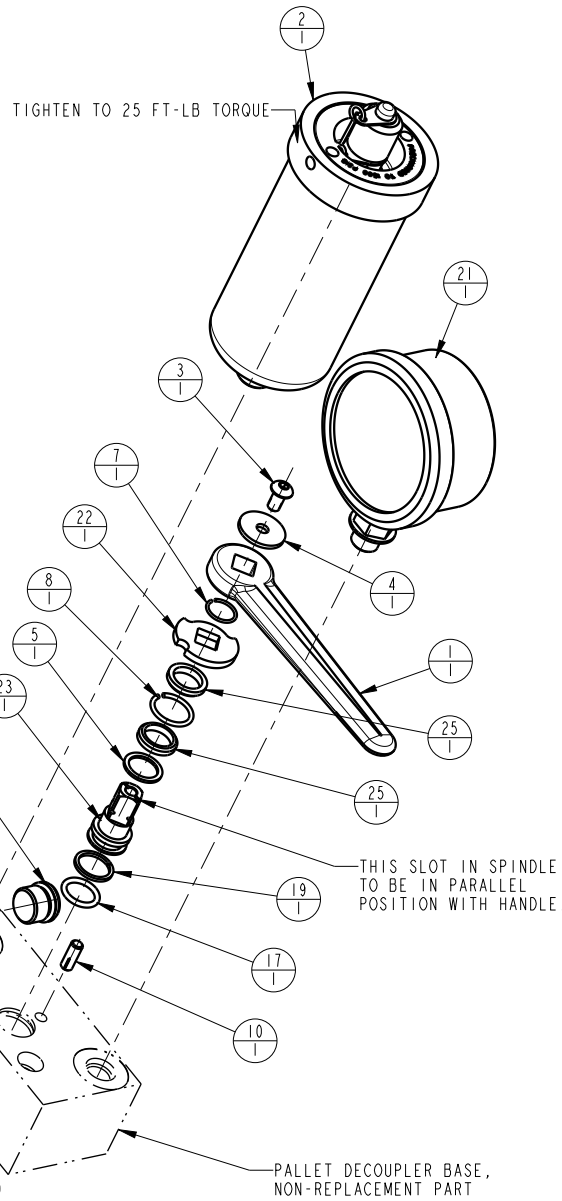

NOTE:  
 1. APPLY LUBRICANT TO ALL SEALS PRIOR TO INSTALLATION.  
 DO NOT USE SILICON TYPE LUBRICANTS.  
 2. SET THE OVER-PRESSURE RELIEF VALVE AT 6,000 PSIG AND  
 THEN INSTALL THE EXPANSION PLUG.

No.	QTY	PART No.	DESCRIPTION	Included in Repair Kit
N/A	N/A	62560000	KIT, REPAIR, PALLET DECOUPLER	
25	2	87010193	SPACER, SPINDLE, STEEL, VALVE, BALL	*
24	1	87010192	BALL, CONTROL, DIRECTIONAL	*
23	1	87010191	SPINDLE, CONTROL, VALVE, BALL	*
22	1	87010190	WASHER, LIMIT, VALVE, BALL	
21	1	72212162	GAUGE, PRESS, HYDR, 10000 PSI	
20	1	70040712	ASSY, ADAPTER/FILTER, PD, 25 MICRON	
19	1	39010042	BU RING, (-014)	*
18	2	39010040	SEAL, VALVE, BALL	*
17	1	39000037	O-RING, (-906)	*
16	1	35349089	PLUG, EXPANSION, 7/16	*
15	1	35349057	RELEASE GUIDE	
14	1	35349056	ROD, RELEASE	*
13	1	30772766	COUPLING, QD, SAE 6, MALE	
12	1	30719706	COVER, DUST, QD, SAE 6	
11	3	30601166	PLUG, SOCH, SAE 6	
10	1	23521018	PIN, GROOVE, TYPE H, 3/16, 1/2 LONG	
9	1	23350057	SPRING, COMPRESSION	
8	1	23012008	RETAINING RING, ROUND, INTL	*
7	1	23002011	RETAINING RING, ROUND, EXT	*
6	1	21440015	SHSS, OVAL POINT	
5	1	21430017	WASHER	*
4	1	21430000	WASHER	
3	1	21410004	BHCS, 10-32 x 3/8, ALY	
2	1	10101601	ASSY, ACC, 3.2 CI, 1500 PSI	
1	1	00107000	HANDLE, VALVE, STRAIGHT	



SEE ADAPTER/FILTER PARTS LIST PL7142

<b>PARTS LIST</b>	 <b>VEKTEK</b> VEKTEK, INC. 1334 E. SIXTH AVE. P.O. BOX 625 EMPORIA, KS. 66801 U.S.A.	
	ASSEMBLIES AFFECTED 56-0001-01	PARTS LIST, ASSY, PD, VERT, 1500 PSI
SIZE A	PL5601	REV Q

Q	5822	RELEASE	JDW	10/05/25
REV	IN ACCORDANCE WITH ECN	EFFECTIVE DATE	REVISED BY	DATE
DRW BY: VANDALSEM	DRAWING STATUS: <b>Released</b>			
DATE: 11-19-90	PRODUCTION APPROVED FOR RELEASED STATUS ONLY			